

Werbetheke Classic Pro



Herzlichen Glückwunsch zum Erwerb Ihrer Werbetafel

Mit der Werbetafel Classic Pro von X-CITE haben Sie ein hochwertiges und funktionales Produkt erworben. Der sachgemäße Umgang garantiert Ihnen langanhaltende Freude an Ihrem System. Bitte lesen Sie daher diese Aufbauanleitung sorgfältig durch, um Schäden durch Fehlbedienungen auszuschließen.

Werbetheke Classic Pro

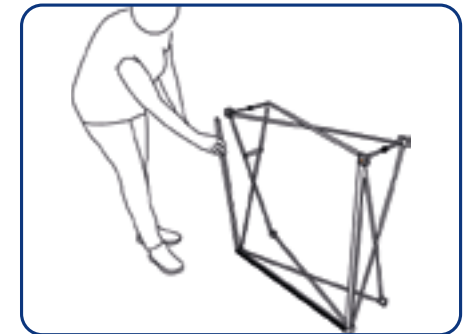
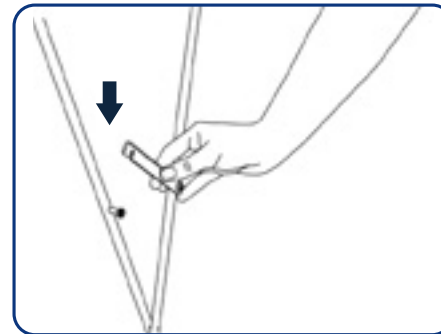
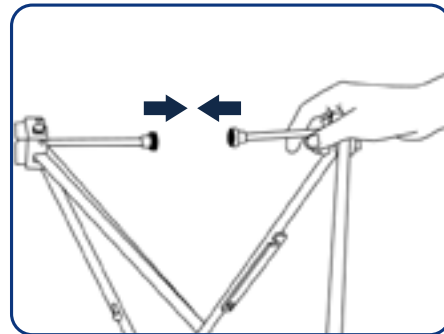
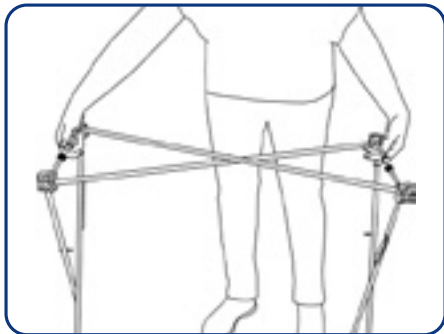
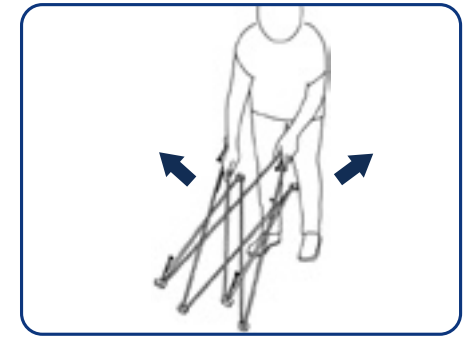
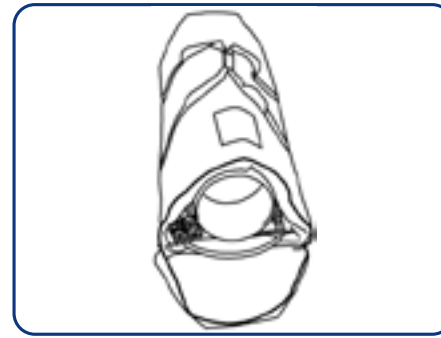
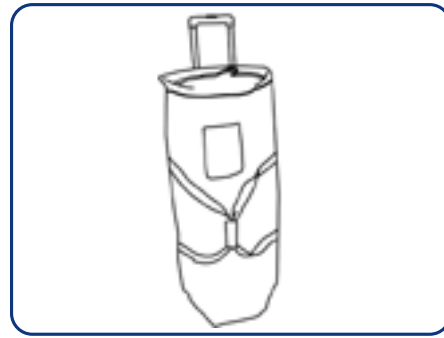
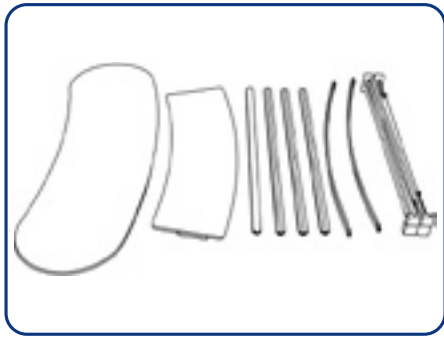

Werbetheke Classic Pro

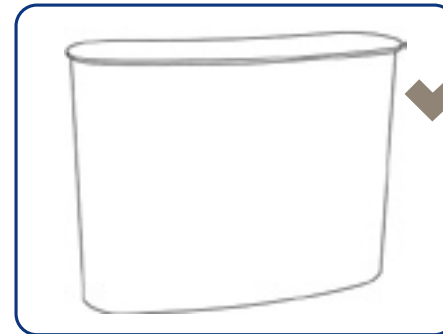
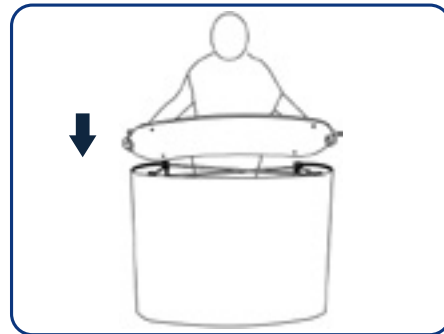
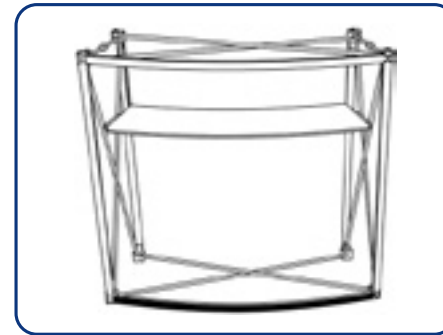
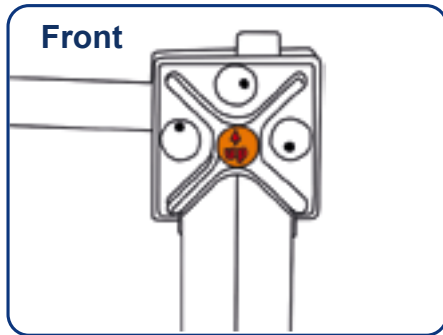

Werbetheke Classic Pro

Haben Sie noch Fragen?

Sie erreichen uns jeden Montag bis Freitag von 9 - 17 Uhr.



X-CITE Werbesysteme GmbH

Gwinnerstr. 40

D-60388 Frankfurt am Main

Tel.: +49 (0) 69 150 49 30 - 00

Fax: +49 (0) 69 150 49 30 - 29

E-Mail: sales@x-cite.com



► [In Google-Maps öffnen](#)